

## THE TECHNICAL RESOURCES FOR AUTOMATION OF SOWING AND PLANT SEEDLINGS

*Ing. Tomáš Stejskal PhD, Ing. Dušan Tresa CSc doc. Ing. Vojtech Anna PhD*

*Department of production systems and robotics of Technical University Kosice,  
Faculty of Mechanical Engineering, Slovakia, **address:** TU Košice, Strojnícka  
Fakulta, Katedra výrobnéj techniky a robotiky, Némcovej 32, 042 00 Košice  
Slovakia.*

¶**Abstract:** *The paper deals with advantages of automatization of plants sowing and precultivation into segment containers and consecutive automatization of planting.*

**Key words:** *automatization, sowing, container, planting*

### 1. INTRODUCTION

In the last two centuries mechanization and automation considerably exert influence up the agricultural industry. Despite great advantages of this development, it is necessary to determine also some definite shady sides.

At first, it is important to determine, what is a real target of automation. Basically, it is possible to define two attitudes:

When the target of automation is to reach the maximum product and profit, then the way tends to the mass production and decreasing of employment rate in the agricultural industry. This way results in the high specialization and thanks to the great productivity, also to reduction of the smaller business forms.

Despite sound advantages of such business, there are some disadvantages as follows:

- Decreasing of total employment rate in the region. People must search for new employment opportunities.
- Thanks to the high pressure of competition in a market, producers decrease the general quality level of products. Especially it is going on degradation of hardly measurable properties related to health and environmental protection.
- In case of the great and sudden changes such as natural catastrophe, sociable changes and likewise, the specialized giant is not flexible enough. The risk of failure is considerably higher.

Second target of automation is unloading the man from hard and stereotype work, but not from all work. This is the “automation with a human face”, because the automation level is limited to the respectable size, by keeping the employment rate. It supports the small and medium farmers. Such automation supports the independence and self-sufficiency of regions. The advantages and disadvantages are reciprocal in comparing with above mentioned model of automation.

Following description of equipment will be focused to support of the second model of automation. Its main signs are:

1. Simply and cheap design mainly with mechanical character.
2. Easy maintenance and self-supporting ability for repairs.
3. Modularity of automatised systems.

## **2. AUTOMATION EQUIPMENT**

### **Plant containers**

Containers are basically assumption for cultivation of healthy and strong plants. It's allowed to earlier terms of growing in the greenhouses. The warmest work is seeding into containers. This work is necessary realise in short time. Basic for construction is periodical structure of containers or trays.

Modern element is a belt container (Fig.1a). This container can roll in form of spiral or rows. Advantage of spiral form is the belt is unconnected. It simplified the construction of planting

machine. The belt container has a large bottom holes and in consequence has to on lattice set. Disadvantage is occurring of vacant places in ordering in the greenhouse.

Modern type of trays is said slot trays (Fig.1b), they have said and bottom cutout. The hols have a significant weight for a right grown of roots of plants. Airy passing at the area of hole stopped the growth of main root and supported said roots.

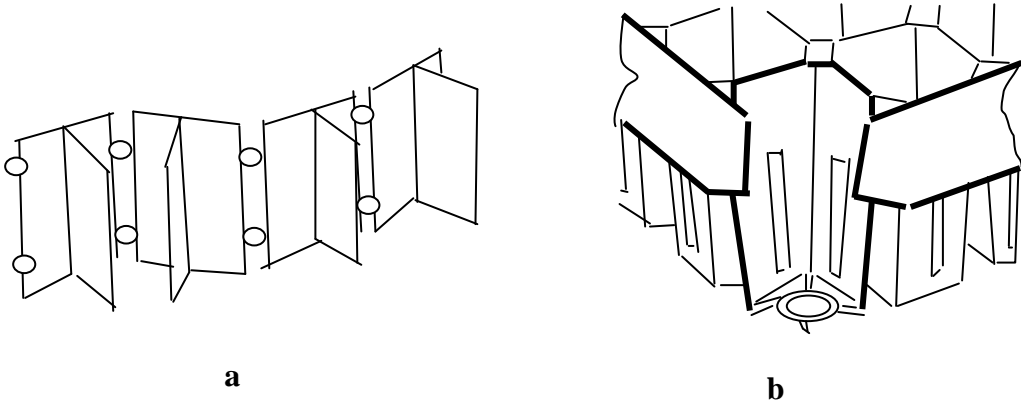
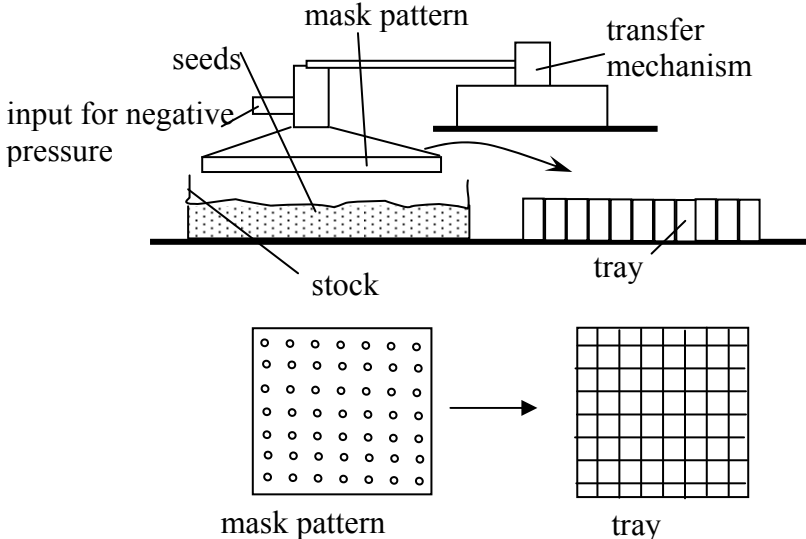

Fig. 1. Belt container and said slot tray

**Seed dispenser**

Manual batching and sowing compare with dispensing of mould into the containers are demanding works [1]. This work is suitable for automation. It can use the following principles:

- a) Capture of seeds with negative pressure.



b) Capture of seeds with wire trap.

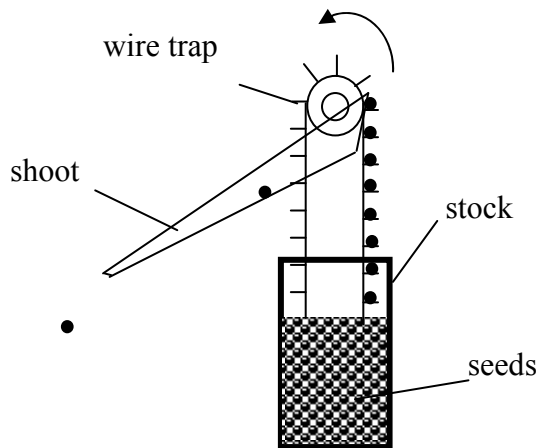

c) Seeds separator.

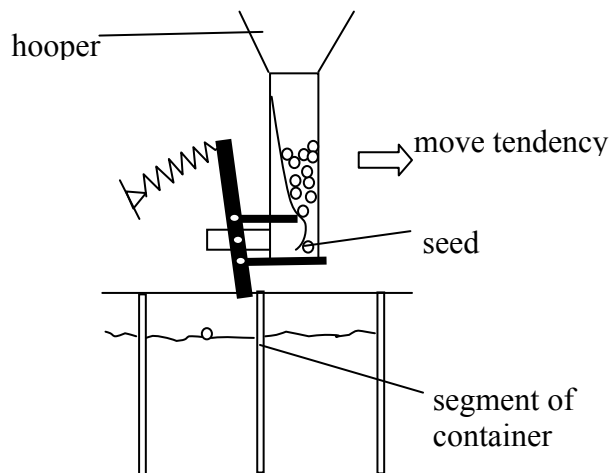

### Movable pallets

Pallets are recommended to be placed into shallow vessels, because beside support system, they provide also moisture keeping. These vessels are located on movable racks. Their advantage is in providing of suitable lighting conditions for plants.

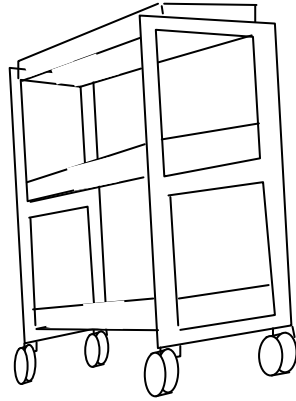

Fig. 2. *Movable pallets system*

### **Planting machines**

In practice, planters require attendance. They are either high performance machines with their own traction, or planter can be connected to other common traction engines.

Non-attendance engines are designed for high-performance only. New task is to design small non-attendance automat (fig.3). Advantages of small automats are as follows:

- eliminate hard work,
- available for small farmers,
- they are modular with minimum width adjusted to 30 cm (fig.4),
- they are easy to repair,
- their filling with different size plants is available.

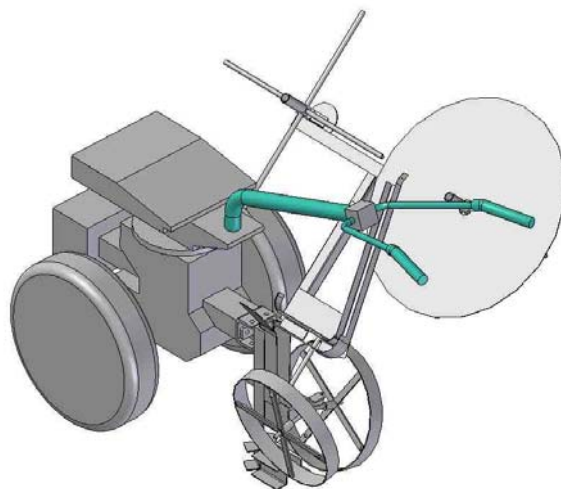

Fig. 3. Proposed automat *planting machine*

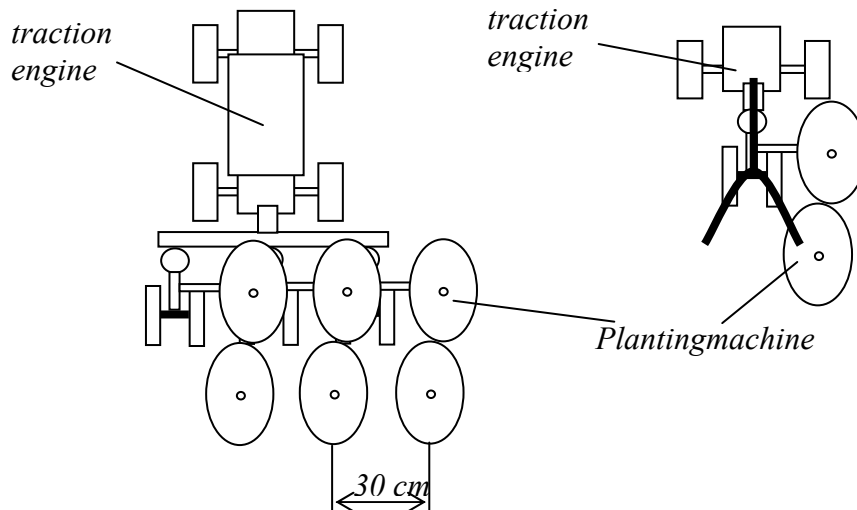

Fig. 4. Modularity of planting machines

### 3. CONCLUSION

Self-sufficiency of region is very important item. It forms basics for good economics. Even more important is resistance, which can be achieved only by diversification of enterprises and so by lower lever of specialisation.

Resistant region must solve unemployment problems and work in harmony.

Previous seasonings meet problems of suitable level of automation. The suitable volume of automation would have come out of requirements of region. Today's is unexercised this one, because the profit is first and foremost. It is in front of the social aspect. Therefore the profit should not achieve to the prejudice of regression. In that case is good also the most level of automation.

Introduced text was elaborated regarding to project "AV4/0116/06 Automat for planting of forest and agricultural plants to reservoirs for automatised planting".

### 4. REFERENCES

- [1] SVETLÍK, J. DOBRANSKÝ, J.: *Automatizácia procesu balenia tavených syrov použitím nového typu zásobníka linky na balenie* In: Acta Mechanica Slovaca Roč. 10, č. 2-A ROBTEP (2006), s. 501-506.s., ISSN 1335-2393