

## TURNING OF ROLL BEARING STEEL 100CR6 OF BAINITE STRUCTURE

*Neslušan Miroslav, Department of Machining and Automation, University of Žilina, Univerzitná 8215/1 010 26, Slovak Republic*

**Abstract:** *This paper deals with turning of bainite roll bearing steel 100Cr6. There is presented significance of the correct heat treatment and its influence on the cutting process through the measurement of cutting forces and tool wear. The paper compares the results of turning of martensite and bainite structure.*

**Keywords:** *bainite, heat treatment, turning, wear*

### 1. INTRODUCCION

Heat treatment is included in the technology process in production of roll bearing parts. Microstructure of these parts after heat treatment consists of martensite and residual austenite. This heat treatment enables to reach the required properties of roll bearing rings, first of all from the point of view of noisiness, life time, etc. On the other hand, martensite structure is hard but with low toughness, there is relatively strong deformation of shape and dimension first of all of the light bearing rings. Some materials have to be cemented because of low contents of carbon. These materials enable to produce roll bearing rings of hard surface and tough core. The disadvantage of this solution is long term and expensive process. Nowadays, there is the next progressive solution of the higher mentioned technology from the point of the heat treatment. It is production of roll bearing rings made of 100Cr6 with bainite structure [1]. Hardness of this structure is about 3 to 4 HRC lower than hardness of martensite structure. On the other hand, its toughness is twice higher in comparison with the martensite structure [1]. Generally bainite materials are very progressive [2]. And so, this paper deals with turning of roll bearing steel 100Cr6 of bainite structure and its comparison with martensite structure. This paper deals with the correct heat treatment of roll bearing steel 100Cr6 treated on the bainite structure from the point of uniform cooling conditions. There are presented information about effect of incorrect cooling conditions during heat treatment and its influence on the cutting process. The next, there is presented comparison of machinability of martensite and bainite structure when turning in this paper.

## 2. EXPERIMENTS

Roll bearing material 100Cr6 of diameter 56 mm, length 250 mm and the thickness 8 mm was used in experiments. Heat treatment and mechanical properties of martensite and bainite structure of 100Cr6 is described in [1]. Conventional hardening enables to produce martensite structure of hardness 62 HRC and toughness 23 J.cm<sup>-2</sup>. Hardness of bainite structure is 59 HRC and toughness 55 J.cm<sup>-2</sup> (cooling in the technical salt 3 hours at temperature 240 °C). Microstructure of machined materials is illustrated in fig.1. Measurements were carried out on lathe SUI 40 with application ceramic inserts DNGA150408S01525 6050.

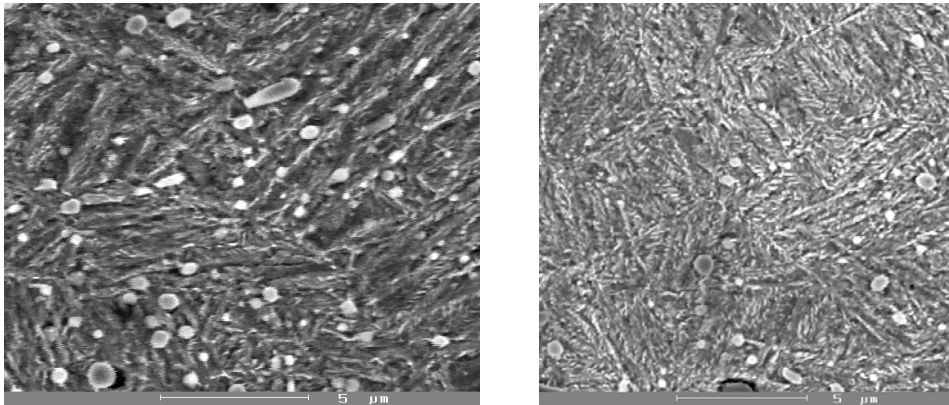

*a) martensite structure*

*b) bainite structure*

**Fig.1** *Microstructure of machined materials after heat treatment [1]*

Analyze of hardness shows that there is not the uniform cooling of the pieces settled according fig.2. In the place of the pieces contact, there is the higher concentration of heat and so the cooling process in this contact is slower. This slower cooling process affects structural changes during the heat treatment and lead to lower hardness (fig.3 b). The next, there is hardness changes not only from the point of view of the tube periphery, but from the point of its length. This is caused by the better conditions for heat transfer near by the end of the piece. There is no visible significant change of hardness at the end of the workpiece (fig.3 a). The higher mentioned hardness change caused by no uniform cooling should be related to the bainite transformation. There are no significant changes in hardness considering the martensite structure (fig. 4b).



**Fig.2** Position of pieces during the heat treatment

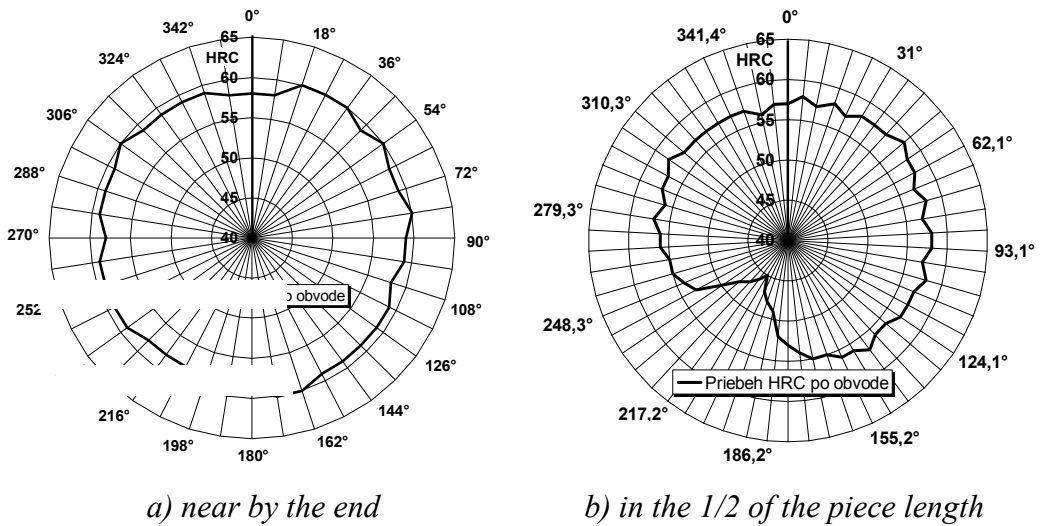

**Fig.3** Change of hardness in the different places of hardened pieces – bainite [3]

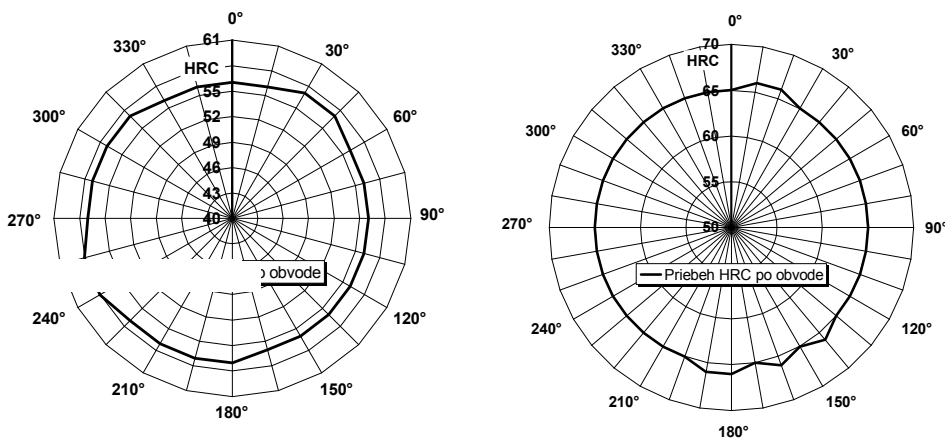
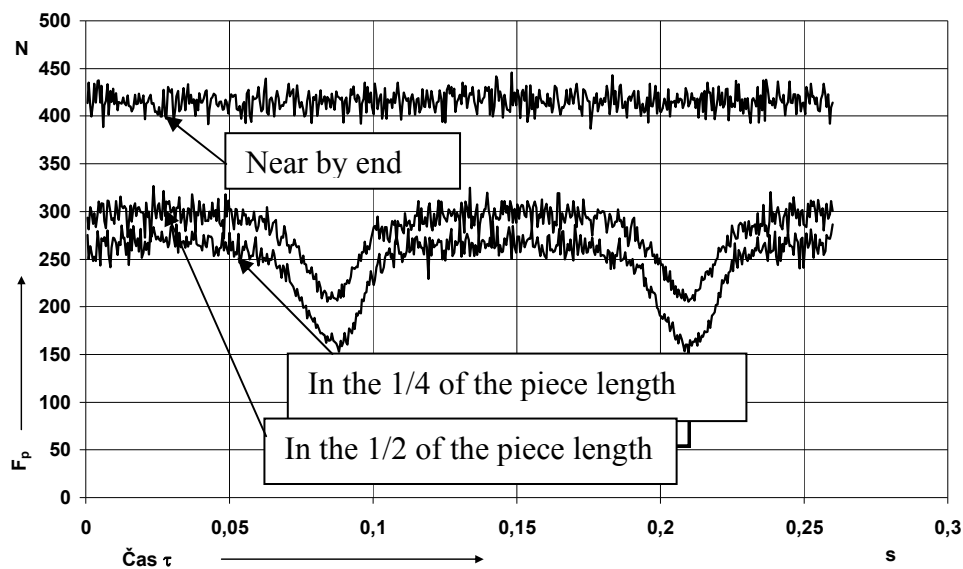

**Fig.4** Hardness profile after correct heat treatment [3]

On the base of this analyse, there were carried out the next heat treatment to reach the uniform cooling of the whole workpiece. There was placed the sole workpiece into the salt and its length was only 125 mm. Analyse of the hardness show that there is no significant difference in the hardness on the periphery of the workpiece and hardness is similiar than that in the fig.3 a. The next, this hardness does not change from the point of view of the piece lenght (fig.4a).

Measurement of cutting forces (measured by the dynamometer KISTLER) shows that incorrect heat treatment influences mechanical load of the tool. Detail analyze of records of cutting forces illustrated in fig.5 shows that hardness change leads to instability of mechanical load because cutting forces strongly depend on hardness of machined structure. There is a visible instability of cutting force  $F_p$  (on fig.5) in the place of the low hardness. Turning of profile without hardness change enable to have the relatively stable cutting process. This situation is illustrated by cutting force record near by end of the piece.

Instability of cutting force is unsuitable because leads to mechanical impacts on the tool. This dynamic character significantly affects tool wear considering the fracture toughness of ceramic tool. While durability of tool is about 57 minutes when turning bainite structure after correct heat treatment (cutting speed  $85 \text{ m}\cdot\text{min}^{-1}$ ), durability of tool is only 41 minutes when turning bainite structure after incorrect heat treatment (fig.8). Similar comparison was obtained for higher cutting speeds. There is more intensive tool wear when machining martensite structure of hardness 62 HRC in comparison with machining bainite structure after correct heat treatment.



**Fig.5** Record of cutting force  $F_p$  in the different places of the piece length 250 mm after bainite heat treatment (there is offset 100 N of  $F_p$  record for near by end of the piece)

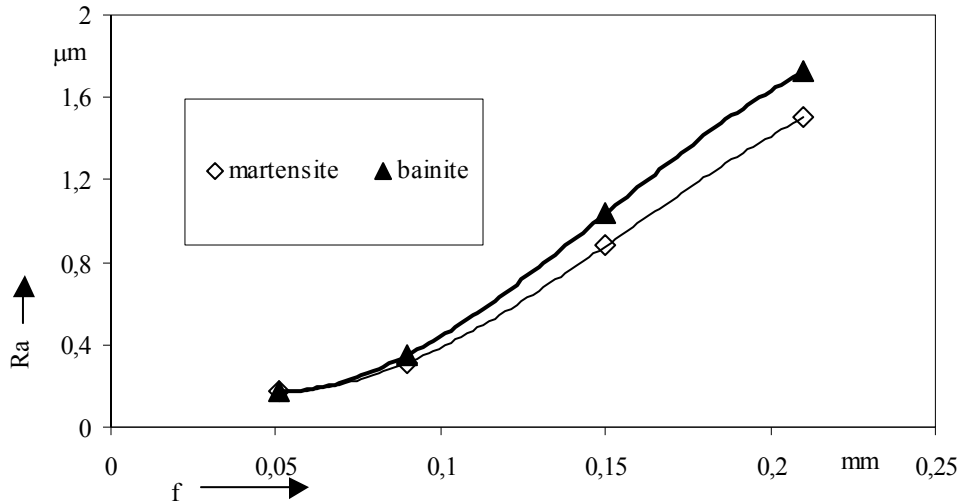

**Fig.6** Influence of feed  $f$  on roughness of machined surface  $Ra$

There is the next negative effect, formation of the nose on the cutting edge when turning softer structure. Incorrect heat treatment causes that hardness in the middle part is lower than that near by the end not only in the place of the pieces contact (fig.3). The nose formation negatively affects surface roughness. On the other hand, there is no significant difference in the surface roughness when turning martensite and bainite structure. This situation illustrates fig.6.

### 3. DISCUSSION OF RESULTS AND CONCLUSION

The results of the higher mentioned analyze shows that correct heat treatment considering the bainite structure significantly influences the following operations together with mechanical properties of the parts and their functionallity. The next, correct heat tretment significantly influences deformation after heat tretment (fig.7). Incorrect heat treatment leads to 5 times higher deviation of the roudness in comparison with the correct heat treatment.

It should be mentioned that problem of the correct heat treatment is not such substantial. The most of the roll bearing rings are thin and short and so the heat accumulation and heat affect is less significant. On the other hand, there is problem of deformation after heat treatment first of all martensite light roll bearing rings. All these effects are closely connected with the allowance for machining. Allowance for machining should enables to remove the deformation after heat treatment and produce part of required precision.

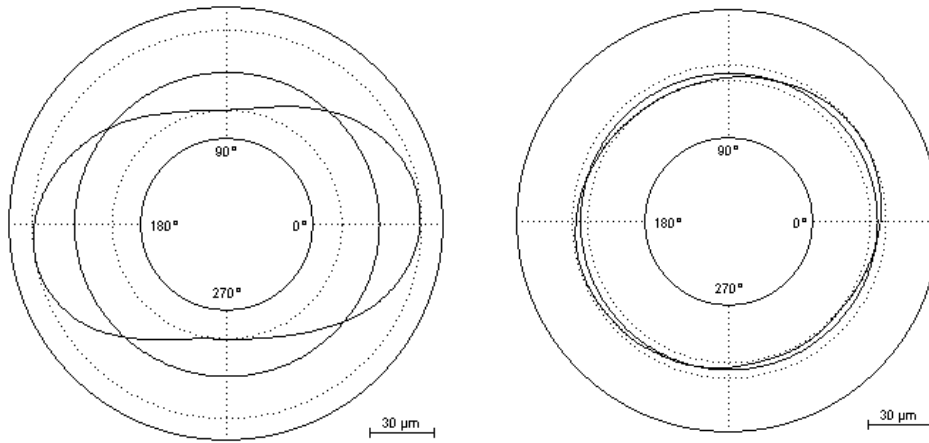

a) profile after incorrect heat

b) profile after correct heat

treatment  $\gamma_k = 36 \mu m$

treatment  $\gamma_k = 7 \mu m$

**Fig.7** Profile of bainite pieces after heat treatment

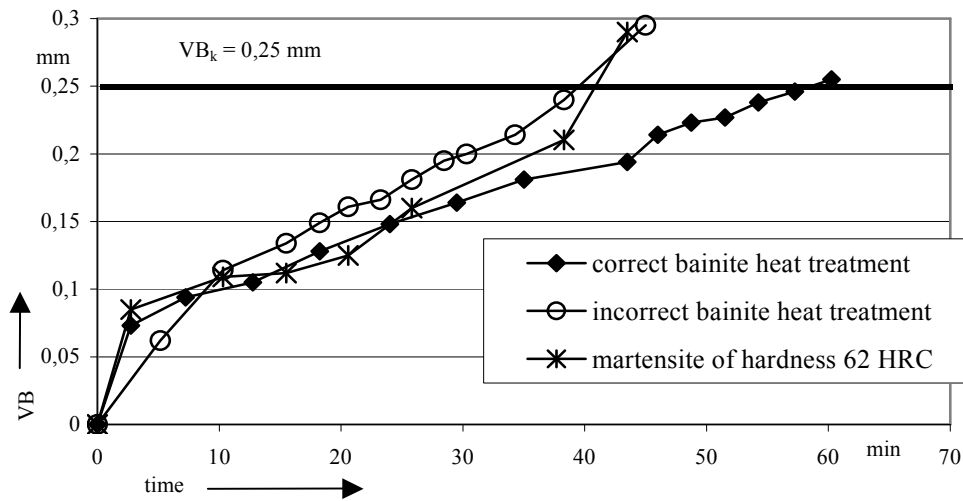

**Fig.8** Process of tool wear,  $a_p = 0,25 \text{ mm}$ ,  $f = 0,09 \text{ mm}$ ,  $v_c = 85 \text{ mm} \cdot \text{min}^{-1}$

#### 4. REFERENCES

1. Hozák, M. – Chalupová, M. – Durmis, I.: *Izotermické zušľachťovanie Cr-Mn ocele na valivé ložiská*. In: Doksem 2004 – Medzinárodný seminár doktorandov, Terchová – Šípková, 2004, s. 5 – 9.
2. Neudeker, J. – Mičian, M. – Meško, J.: *Bainitická tvárna liatiny*. DOKSEM 2001, Súľov, s. 107 – 111.
3. Tatár, L.: *Sústruženie ložiskovej ocele 14 109 s bainitickou štruktúrou*, DP SĽF, ŽU, KOA 2005